

Product Description:

The VCL-SafeComm, 16 E1 Links (48 E1 Ports), 1+1 Automatic Protection Switching Equipment may be used to protect upto 16 E1 Links (48 E1 Ports), point-to-point links and provide an alternate communication route to each E1 Link between any two E1 points. In the event of the failure of the primary (Main) E1 communication route, the VCL-SafeComm, 16 E1 Links (1+1 Automatic Protection Switching Equipment) automatically switches the E1 traffic to a secondary (standby) E1 route.



**VCL-SafeComm, 16 E1 Links (48 E1 Ports)
1+1 Automatic Protection Switching (APS)**

The VCL-SafeComm, 16 E1, 1+1 Automatic Protection Switching equipment is available in a 2U high chassis, which may be mounted in any DIN standard, 19-Inch rack.

This product allows the user to design 1+1 (protected) redundant E1 routes on similar (fiber-fiber), or complementing (fiber-radio) transmission mediums.

The criterion for switching between the primary (main) and the secondary (protected / standby) routes is user programmable. Criterion for switching between the primary (main) and the secondary (protected / standby) routes may be Loss-Of-Signal on E1 links, or AIS (All-Ones AIS alarm) condition. The criterion for switching time and recovery time between the primary (main) and the secondary (protected / standby) routes is user programmable.

Data transported on the E1 Links is transparent and protocol independent.

Applications:

Providing 1+1 alternate paths between any two E1 Transmission mediums (active+standby). E.g.:

- Fiber/Fiber
- Radio/Fiber
- Radio/HDSL
- Fiber/HDSL etc.

Example: The user may deploy the VCL-SafeComm, 16 E1, 1+1 Automatic Protection Switching Equipment to provide an alternate communication route between an optical fiber link and a radio link between any two points. In the event of the failure of the primary (optical fiber) link the E1 is automatically switched to the alternate route over the E1 radio, thus ensuring maximum uptime on all such 1+1 protected E1 Links.

Once the primary (optical fiber) E1 Link on the optical fiber is restored, the VCL-SafeComm, 16 E1, 1+1 Automatic Protection Switching Equipment automatically restores the communication to the primary (optical fiber) E1 Link. The switching time and restoration criterion is user programmable.

Application Diagram:

Figure (application) # 1

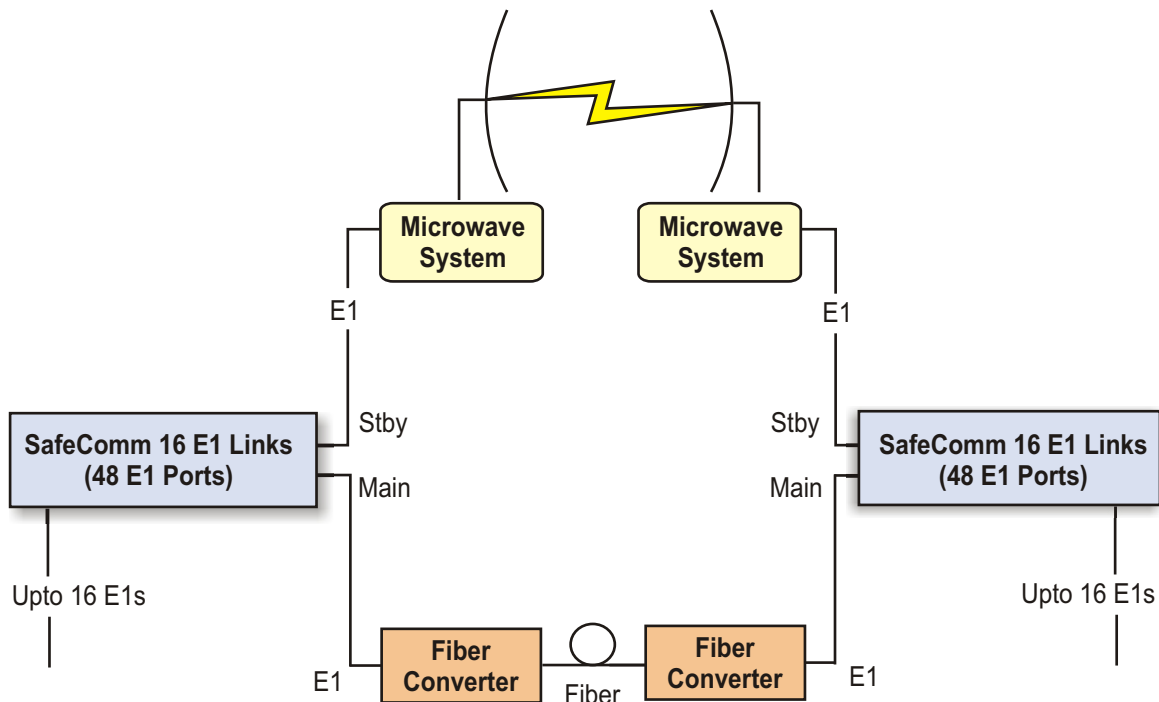

Point-to-Point Application: May be used in a point-to-point configuration to provide 1+1 Protected /Alternate Routing Path between any two points, using diverse (or similar) E1 transmission mediums.

Figure (application) # 2

TYPICAL STAR CONFIGURATION

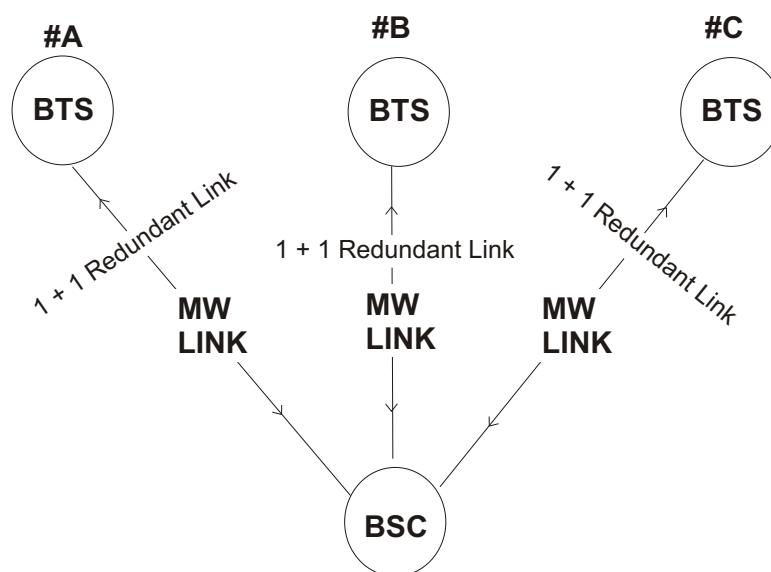

Point-to-Multipoint Application: To provide 1+1 Redundant E1 Link(s) between a single (BSC) location and multiple (BTS) locations using diverse (or similar) E1 transmission mediums.

Figure (application) # 3

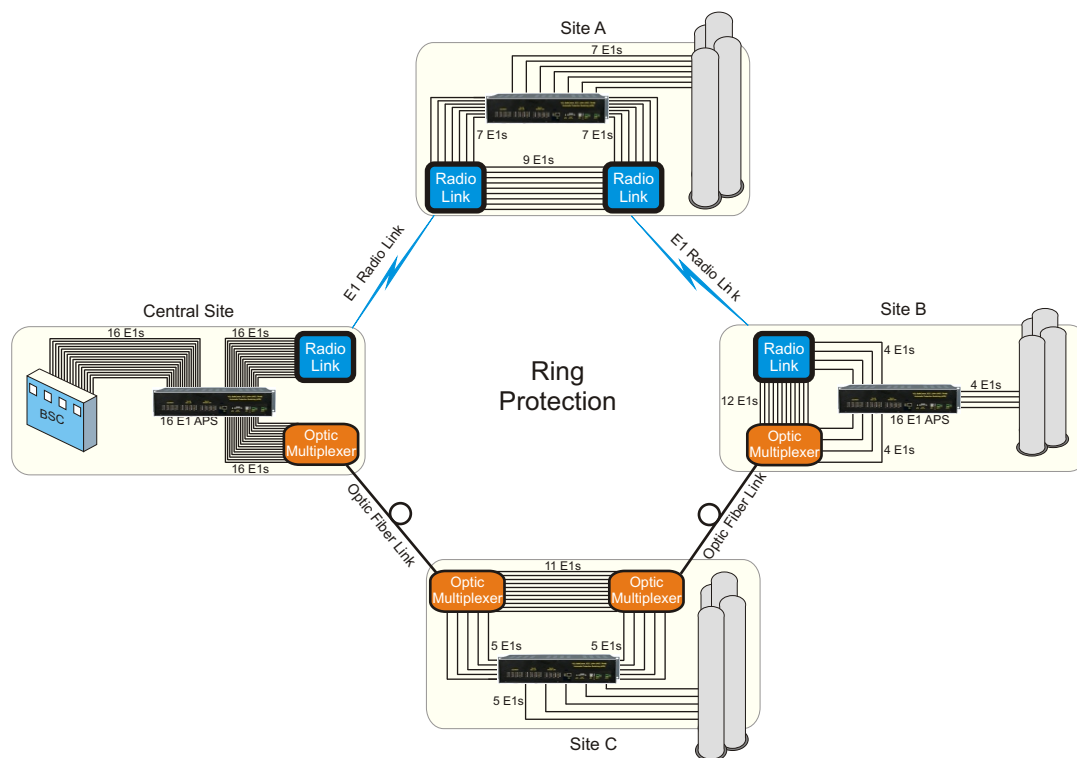

Application to provide resilient (protected) E1 rings over PDH networks:

The VCL-SafeComm may also be used in 1+1 redundant (protected) E1 rings on PDH networks using diverse (or similar) E1 transmission mediums.

How It Works - VCL-SafeComm™ (With Path Protection Switching)

During normal operation, VCL-SafeComm sends duplicate traffic across both the working and dedicated protection E1 facilities while continuously maintaining the performance of both links to determine which link shall be utilized.

Figure (application) # 4

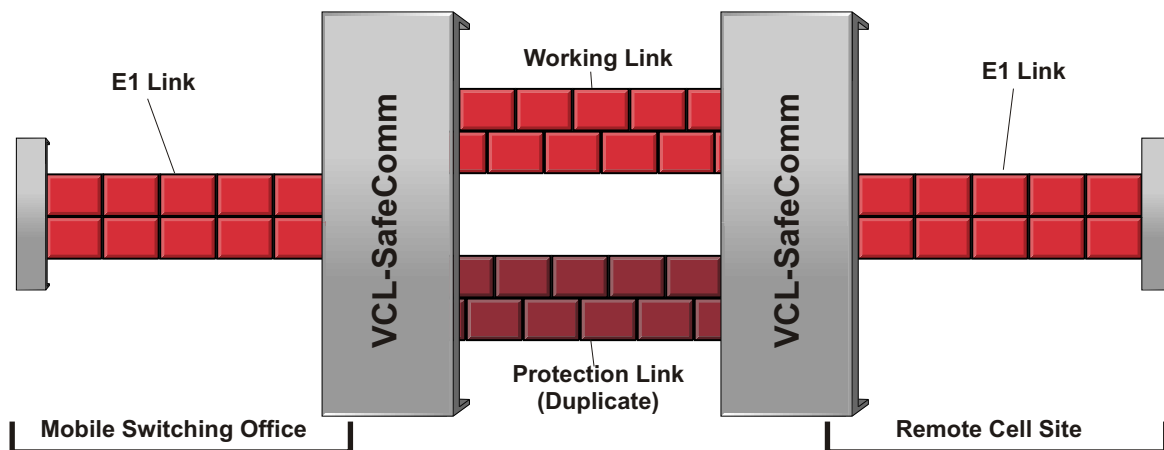

Features & Highlights:

- High density protection switching equipment (upto 16 E1 Links; i.e. 48 E1 Ports)
- To provide an independent point-to-point, protected E1 Link between two “E1 USER PORTS” on similar (example fiber-fiber), or dissimilar (fiber-radio) mediums
- To provide 1+1 E1 redundancy
- Remote system configuration and management interface through "CLI" text based commands using Telnet and GUI (Graphical User Interface)
- Provide 1+1 Protection Routing / Path between BSC and BTS
- These ensure that mission critical voice, data, control and management traffic are properly supported and maintained even during E1 backhaul facility outages. When the primary (working) link fails, the E1 traffic is automatically switched to the standby (secondary) link to ensure maximum uptime
- Through the comprehensive remote configuration and alarm management capabilities of the VCL-SafeComm, 16 E1, 1+1 Automatic Protection Switching Equipment the product may be used to improve network reliability and control
- Traffic Protection
- Alternate Facility Advantages
- Service Differentiation Agreements
- Increased Network Reliability Resilience
- Media and Path Diversity
- Remote Management
- Alarm logging and monitoring.

Benefits:

- Competitive
- Service Level
- Back-haul Network
- Technology Migration
- User Programmable 1+1 Protection Parameters:
 - › Loss Of Signal (LOS)
 - › Alarm Indication Signal (AIS)
 - › External open/close dry contact signal.

User programmable criterion for switching between Active and Standby E1 Links at the customers premises:

Loss of E1 Signal (LOS)	The Loss of Signal condition in a E1 may occur due to: <ul style="list-style-type: none"> • The failure of the E1 Port of the customer premises equipment. • Or due to loss of power to the customer premises equipment. • Or due to the disconnection of the E1 Cable between the protection Switch and the E1 Port of the customer premises equipment.
Alarm Indication Signal (AIS)	This Alarm indicates that a E1 link error has occurred.
External Dry Contacts Signal	This indicates the External Dry Contacts open/close state.

Security and Password Features

System Access, Control and Management Options:

- Telnet
- SSH
- CLI Control Interface (HyperTerminal or VT100)
- SNMP V2 Traps (MIB File provided)
- Windows based GUI (Graphical User Interface) for easy configuration, management and access.
Ability to monitor multiple units from a single NMS.

OAM: Operation and Management Ports

- RS232 Serial Port
- USB COM Port
- 10/100BaseT Ethernet for remote access.

Security and Protection

- Secured Access via SSH V2
- Password Protection: Password Protection in compliance with the mandatory clauses of the GR-815-CORE-2 specifications for secured access control.
- Logging: Maintains a log of all successful and un-successful attempts.
- Logged information includes the ID and the IP address of the accessing entities.
- Alerts the administrator if the un-successful logging attempts exceed three.
- Security Audit: All access logs for up to 30 days are maintained for security audit purposes.
- Security log entry of any request or activity including that user-ID (including IP address, if applicable), to establish user accountability
- Report Generation / Audit Trail
- Security Administration.

Mode of Operation:

There are three modes in which the VCL-SafeComm E1, 1+1 Automatic Protection Switch can be configured to operate in:

1. AUTOMATIC SWITCHING MODE
2. EXTERNAL TRIGGER SWITCHING MODE
3. MANUAL SWITCHING MODE.

AUTOMATIC SWITCHING MODE:

The VCL-SafeComm can be configured to operate in an AUTOMATIC SWITCHING MODE. In the automatic mode, the switch shall automatically switch and re-route the E1 circuits from the MAIN route to the STANDBY route if there is an AIS or a LOS (LOSS OF SIGNAL) alarm, on the MAIN E1 link route.

Similarly, in the automatic mode the switch shall automatically switch back and re-route the E1 circuits from the STANDBY route to the MAIN route, upon the restoration of the service on the MAIN E1 link route.

All switching parameters and link restoration parameters are user programmable.

EXTERNAL TRIGGER SWITCHING MODE:

Sometimes the user wants to switch the E1 circuits between the MAIN route and the STANDBY route when some external event occurs.

In the EXTERNAL TRIGGER MODE, the user can switch between the MAIN E1 route and the STANDBY E1 route when an external trigger (such as an closed/opened physical contact) is applied to the switch.

This unique feature is used by certain radios equipment suppliers, where they apply an external trigger to switch and re-route the E1 circuits between their main E1 radios and standby E1 radios.

MANUAL SWITCHING MODE:

In Manual Switching Mode, the user shall use manual Telnet commands to switch the E1 circuits between the MAIN route and the STANDBY route, manually, using Telnet commands.

In this mode the AUTOMATIC MODE and the EXTERNAL TRIGGER MODE are both disabled and the manual commands over ride all other modes.

Front View

AC Version

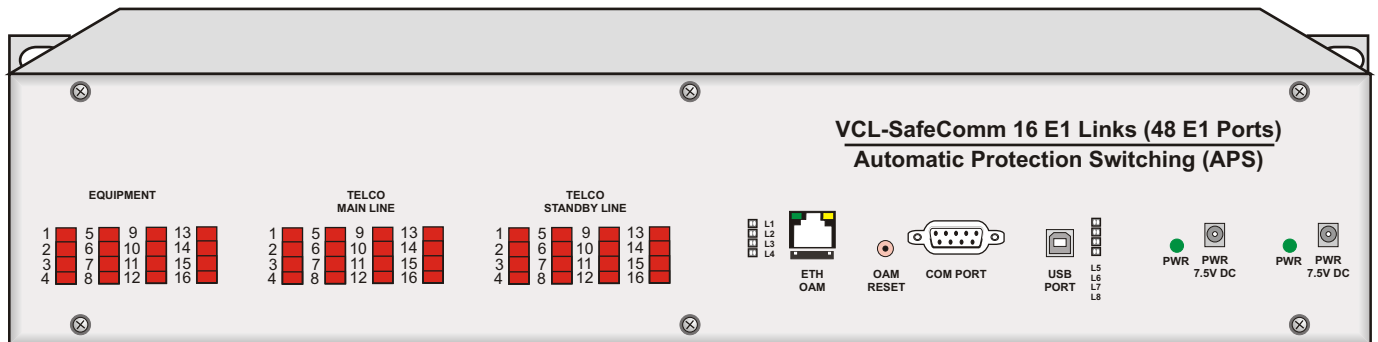

DC Version

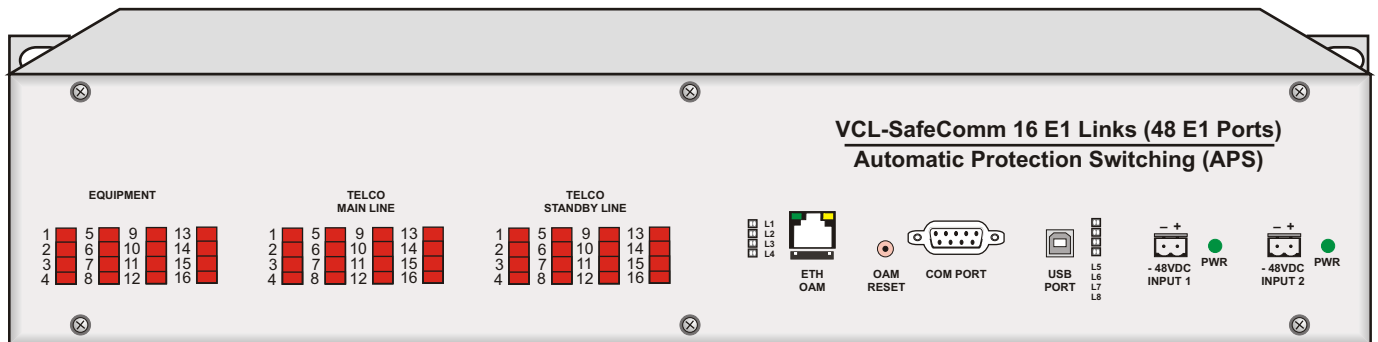

Technical Specifications

Network Interface

Number of Interfaces	16 Equipment E1 Links (E1s) 16 Telco Main E1 Links (for Equipment-A) 16 Telco Standby E1 Links (for Equipment-B)
Line Rate	E1 - 2.048 Mbps
Line Code	HDB3
Frame Structure	G.704
Jitter Tolerance	As per ITU-T G.823
Output Jitter	< 0.05 UI (in the frequency range of 20 Hz to 100 KHz)
Nominal Line Impedance	120 Ohms Balanced RJ-45
Pulse Mask	As per ITU (CCITT) Rec. G.703
Loss and recovery of frame alignment	As per clause 3 of ITU (CCITT) G.732
Loss and recovery of multiframe alignment	As per clause 5.2 of ITU (CCITT) G.732

AC Power Supply Specifications

Output voltage of AC Adapter	100 - 240 Volt AC
Range of input AC voltage	100 V to 240 V AC, 50Hz / 60Hz.
System Input voltage	7.5 V DC to 9.0 V DC, DC input polarity protection.
Maximum full load output current	2.5 A at 7.5 V DC / 9.0 V DC
Input voltage reversal protection	Provided in the Card
Efficiency at full load	> 86%

DC Power Supply Specifications

Input DC voltage - Dual Input	-48V DC (nominal)
Range of input voltage	-18V to -72V DC
System voltage	3.3V
Input voltage reversal protection	Provided in the Card
Short circuit protection	Provided
Power Consumption	≤ 10W

Operations and Maintenance (OAM) Interfaces

- RS232 serial interface for local terminal access
- USB serial interfaces for local terminal access
- 10/100BaseT Ethernet Interface for remote access over an IP network.

Command Language

- Command Line Interface (English text commands)

Compliance / Regulatory

- EMC FCC Part 15 Class 2
- Safety - UL 1459 Issue 2
- Operation ETS 300 019 Class 3.2
- Storage ETS 300 019 Class 1.2
- Transportation ETS 300 019 Class 2.3

Management and Monitoring

- RS232 serial, USB serial interfaces for local terminal access.
- 10/100BaseT Ethernet Interface for remote access over an IP network.
- Encrypted Password Protection.
- Telnet – Remote access over IP links.
- SSH – Secured remote access using Secure Shell Protocol over IP links.
- SNMP Traps and NMS for real time remote monitoring and management over an IP network.
- Automatic Link Test feature link testing at user programmable periodical intervals.
- Visual I/O status LED Display.

NMS (with Telnet) XPort Specification

Network interface	RJ-45 Ethernet 10BaseT or 100BaseT-TX (auto sensing)
Compatibility	Ethernet Version 2.0 IEEE802.3
Protocols supported	ARP, UDP/IP, TCP/IP, Telnet, ICMP, SNMP, SSH
LEDs	10Base-T and 100Base-TX Activity, Full/half duplex
Management	SNMP, Serial login, Telnet login, SSH
EMI Compliance	<ul style="list-style-type: none"> - Radiated and conducted emissions complies with Class B limits of EN55022:1998 - Direct and Indirect ESD complies with EN55024:1998 - RF Electromagnetic Field Immunity complies with EN55024:1998 - Electrical Fast Transient/Burst Immunity complies with EN55024:1998 - Power Frequency Magnetic Field Immunity complies with EN55024:1998 - RF Common Mode Conducted Susceptibility complies with EN55024:1998

Mechanical Specifications

Rack mounting	Standard 19-Inch. DIN Rack
Height	44.00 mm.
Depth	260.00 mm.
Width	477.00 mm.
Weight	4.3 Kg.

Temperature

Operating	0°C to 50°C
Humidity	5% to 95% Non-Condensing

Ordering Information

S. No.	Part No.	Product Description
1.	VCL-1431-APS-16/48E1-DLX-1AC220	VCL-SafeComm 16E1 Links (48E1 Ports) 1+1 Automatic Protection Switching (APS) Equipment 19" Shelf 2U High Rack-Mount Version Supports: - Upto 48 x E1 Port [120Ω RJ45F] [16 for Main E1, 16 for Primary E1, 16 for Secondary E1] - 1 x 100-240V AC Power Supply Input [Adapter Option] - 1 x System Core Cables, Installation accessories, Documentation, System User Manual Disk etc (Set) - OAM : 10/100BaseT Ethernet RJ45 (SNMP, Telnet) and Serial Port (USB and DB-9 COM Port)
2.	VCL-1431-APS-16/48E1-DLX-2AC220	VCL-SafeComm 16E1 Links (48E1 Ports) 1+1 Automatic Protection Switching (APS) Equipment 19" Shelf 2U High Rack-Mount Version Supports: - Upto 48 x E1 Port [120Ω RJ45F] [16 for Main E1, 16 for Primary E1, 16 for Secondary E1] - 2 x 100-240V AC Power Supply Input [Adapter Option] - 1 x System Core Cables, Installation accessories, Documentation, System User Manual Disk etc (Set) - OAM : 10/100BaseT Ethernet RJ45 (SNMP, Telnet) and Serial Port (USB and DB-9 COM Port)
3.	VCL-1431-APS-16/48E1-DLX-2DC024	VCL-SafeComm 16E1 Links (48E1 Ports) 1+1 Automatic Protection Switching (APS) Equipment 19" Shelf 2U High Rack-Mount Version Supports: - Upto 48 x E1 Port [120Ω RJ45F] [16 for Main E1, 16 for Primary E1, 16 for Secondary E1] - 2 x -24V DC Power Supply Input - 1 x System Core Cables, Installation accessories, Documentation, System User Manual Disk etc (Set) - OAM : 10/100BaseT Ethernet RJ45 (SNMP, Telnet) and Serial Port (USB and DB-9 COM Port)
4.	VCL-1431-APS-16/48E1-DLX-2DC048	VCL-SafeComm 16E1 Links (48E1 Ports) 1+1 Automatic Protection Switching (APS) Equipment 19" Shelf 2U High Rack-Mount Version Supports: - Upto 48 x E1 Port [120Ω RJ45F] [16 for Main E1, 16 for Primary E1, 16 for Secondary E1] - 2 x -48V DC Power Supply Input - 1 x System Core Cables, Installation accessories, Documentation, System User Manual Disk etc (Set) - OAM : 10/100BaseT Ethernet RJ45 (SNMP, Telnet) and Serial Port (USB and DB-9 COM Port)

