

4E1 over Packet / TDM over IP

Product Overview

Valiant's 'VCL-E1oP' E1 over Packet (4 E1 Port FE Version) TDM over IP equipment supports transmission of up to 4 x E1 links over IP / Ethernet, MEF or MPLS Pseudo-wire networks.

The 'VCL-E1oP' E1 over Packet (4 E1 Port FE Version) TDM over IP equipment, equipped with a powerful ARM-Cortex Processor which provides a highly reliable clock recovery mechanism for low jitter and wander control, even under variable network conditions.

4 x E1 Port E1oP (E1 over Packet) TDM over IP equipment is available with various Electrical (10/100BaseT) and Optical (100BaseFX) Ethernet port options which allow the users to implement 1+1 add-drop (Drop-Insert), Ethernet link redundancy (using Port Trunking / Port Bonding) and 802.1p based QoS mechanisms for network optimization.

The 'VCL-E1oP' E1 over Packet (4 E1 Port FE Version) TDM over IP equipment also optimizes on the network usage, such that the bandwidth used by the E1oP equipment on the packet network is limited to the corresponding to the number of E1 ports and the time-slots that are being transported over the Ethernet / packet network.



Purpose of TDM over Packet technology

Telecom companies and enterprise users can save significant network and equipment cost and generate additional revenue by offering different types of services over a single packet-switched infrastructure by the use of E1oP equipment. The E1oP equipment is also suitable for connecting to Ethernet / packet wireless equipment to achieve fast deployment of E1 services over wireless Ethernet networks. One particular application is to build E1 links with low cost Wireless LAN bridges, replacing expensive TDM / E1 microwave radios.

The 4 x E1 over Ethernet (VCL-E1oP) multiplexer may be used to provide legacy TDM services over Ethernet optical fiber, or wireless Ethernet/IP networks.

How the TDM over Packet (4 E1 Port FE Version) equipment works

The E1 data streams received on the E1 interfaces are converted by the E1oP engine of the E1oP equipment to Ethernet data packets (of a fixed size) and transported over the Ethernet network with UDP / IP, MEF or MPLS headers. At the receiving end the E1oP reconstructs the original data streams by removing the IP, MEF or MPLS headers and converts the Ethernet data packets back to E1 frames using highly reliable and accurate clock recovery mechanism. The 'VCL-E1oP' (4 E1 Port FE Version) offers the user a choice of standard, E1 to packet and packet to E1 conversion mechanisms that include SAToP and CESoPSN technologies.

Hardware Highlights

- 19-Inch rack mountable
- 1U form factor (44mm)
- 1+1 Redundant Power Supplies, AC and DC, or AC plus DC.
- Redundant power supply inputs.
- Extended Temperature Range: (-20°C to +60°C)
- EMI / EMC Complaint
- Real Time battery backed clock with life in excess of 10 Years
- Power over Ethernet (PoE), PSE type 2 - Optional

E1 Clock recovery and synchronization techniques:

- Adaptive Clock Recovery (ACLK)
- Recovered Clock (RCLK) / Loop-Timed Clock
- Asymmetrical (One-Clock and Two-Clock) Clock
- Synchronization to an External Clock (ECLK)
- Synchronization to an Internal Clock
- Automatic clock priority selection with fall back
- Plesiochronous Clocking.

Key Features - E1 and E1oP Interface

- Supports 4 independent E1 interfaces.
- Internal, External, Adaptive, Recovered clock and Asymmetrical (One-Clock and Two-Clock) options for the E1 TDM port synchronization. Automatic clock priority selection with fall back.
- Supports CESoPSN payload mechanism to support the fractional E1 with data rate of 64Kbps to 2.048Mbps (DS0 timeslot level). User configurable data rate from 64kbps to 2048kbps, in steps of 64kbps.
- CESoPSN payload mechanism feature allows the user to optimize the packet switched network by limiting its usage to the corresponding number of time slots carried by an E1 channel.
- Supports SAToP payload mechanism to transport full E1 (transparent to the structure of the TDM frame useful for transporting framed / unframed E1 channels).
- Supports IETF-PWE3 (pseudo-wire) transport mechanism.
- Supports IP, MPLS and MEF8 (Metro-Ethernet) tagging.
- Supports three E1 framing modes - Framed, Unframed and Multi-framed with CAS signaling.
- Supports network latency / packet delay variation / jitter buffer of up to 512ms.
- Absolute and Differential timestamps.
- Jitter and Wander conforms to G.823 / G.824 and G.8261 and TDM specifications.
- 120 ohms balanced E1 interfaces. Optional 75 Ohms BNC interface (120 Ohms to 75 Ohms cables provided).
- E1 local and remote loop-back (RLOOP) facility for testing and diagnostics.

Key Features - Ethernet / IP Network Interface

- Optical SFP based (100Base-FX) and Electrical (100Base-T) Ethernet port and PoE options
- 4 x Fast Ethernet ports in following combination:
 - 4 x 10/100BaseT (Copper) Ethernet ports - **Default**
 - *2 x FE Copper Ports + 2 x FE PoE Ports
 - *2 x 100BaseFX Optical Ports + 2 x FE Copper Ports
 - *2 x 100BaseFX Optical Ports + 2 x FE PoE Ports**Optional*
- Power over Ethernet (PoE) (available options as above). Meets and exceeds the Telcordia GR-1089-CORE Lighting and Power Contact Protection requirements.
- PoE Class 4 (25.5 Watts)
- PSE type 2
- Point-to-point and point-to-multipoint applications based on IP addressing.
- Supports drop and insert applications.
- 1+1 Ethernet Link Redundancy / Redundant Link Protection.
- Supports QoS, 802.1q and 802.1p based packet priority.
- Q-in-Q Tagging.
- Flow Control in an Ethernet Packet Networks (Regulating Traffic)
- Port / Customer based bandwidth allocation (Port Rate Limiting – Ingress and Egress)
- DSCP and 802.1Q / 802.1p based packet tagging and prioritization
- MPLS, MEF and UDP tagging for Ethernet traffic.
- Separate IP Address for TDM traffic and equipment management.
- VLAN tagging for TDM traffic and equipment access / management.

- User configurable MTU (E1oP payload) packet size up to 1500 Bytes.
- 802.1Q Tag based VLANs Supports 1-4095 VLAN Ids.
- Supports Packet priority assignment (IP Diffserv / DSCP).
- UDP-specific “Special” Ethernet type.
- In band VCCV ARP.
- Broadcast DA.

Key Features explained:

- **VLAN Based Priority (Classifying Services)** - VLAN based Priority feature allows the user to assign priorities to different VLANs carrying various types of services / traffic according based on user categories and preferences. The user may assign highest priority to TDM (E1/E3) traffic and Ethernet services on a lower priority. User may also configure which TDM link should be given preference over the other TDM links when the uplink bandwidth falls below a particular threshold.
- **Flow Control in an Ethernet Packet Networks: (Regulating Traffic)** - Flow Control feature allows the user to regulate Ethernet traffic flow to minimize packet loss due to data bursts.
- **Port / Customer based bandwidth allocation (Port Rate Limiting)** - Port based Ingress Ethernet Rate Limiting allows the user to assign the bandwidth as per port / service requirements, in addition to provisioning traffic by using 802.1Q and 802.1p VLANs and packet priority.

Key Features - System Management, Monitoring and Alarm Interfaces

- External Alarm - Dry contact relay alarms are also available at rear of the system to connect the system to an external alarm.
- NMS (Network Management System) to monitor multiple units from single Central Location.
- Supports system temperature monitoring with High Temperature threshold and Low Temperature threshold alarms and SNMP Traps.
- Supports SNMP V2 Monitoring and Traps.
- Self-test for checking system errors upon system bootup.
- Event Logging.
- Clock Performance Alarms.
- Network Performance Alarms.
- Network Performance Monitoring and Diagnostics.
- Online / remote upgrade of firmware.

OAM: Operation and Management Ports

- RS232 (DB9) Serial Port.
- 10/100BaseT Ethernet Management for In-band remote access.

System Access, Control and Management Options

- Telnet.
- CLI Control Interface (HyperTerminal or VT100).
- SNMP V2 Traps (MIB File provided).
- Windows based GUI (Graphical User Interface) for easy configuration, management and access. Ability to monitor multiple units from a single NMS.
- Password Protection.1

Application Diagram

E1oP in Cellular Backhaul

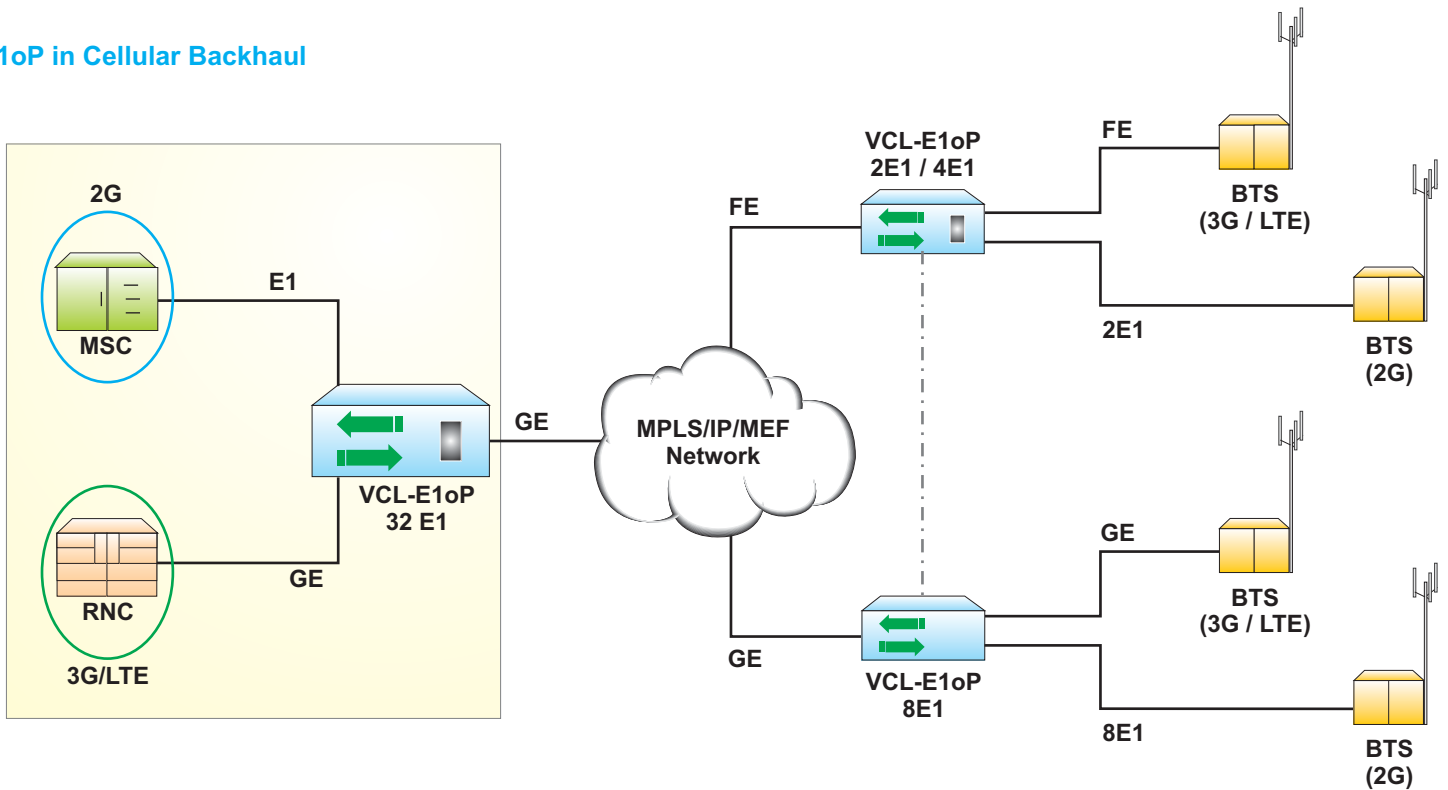

Typical Application Diagram in Wireless Network

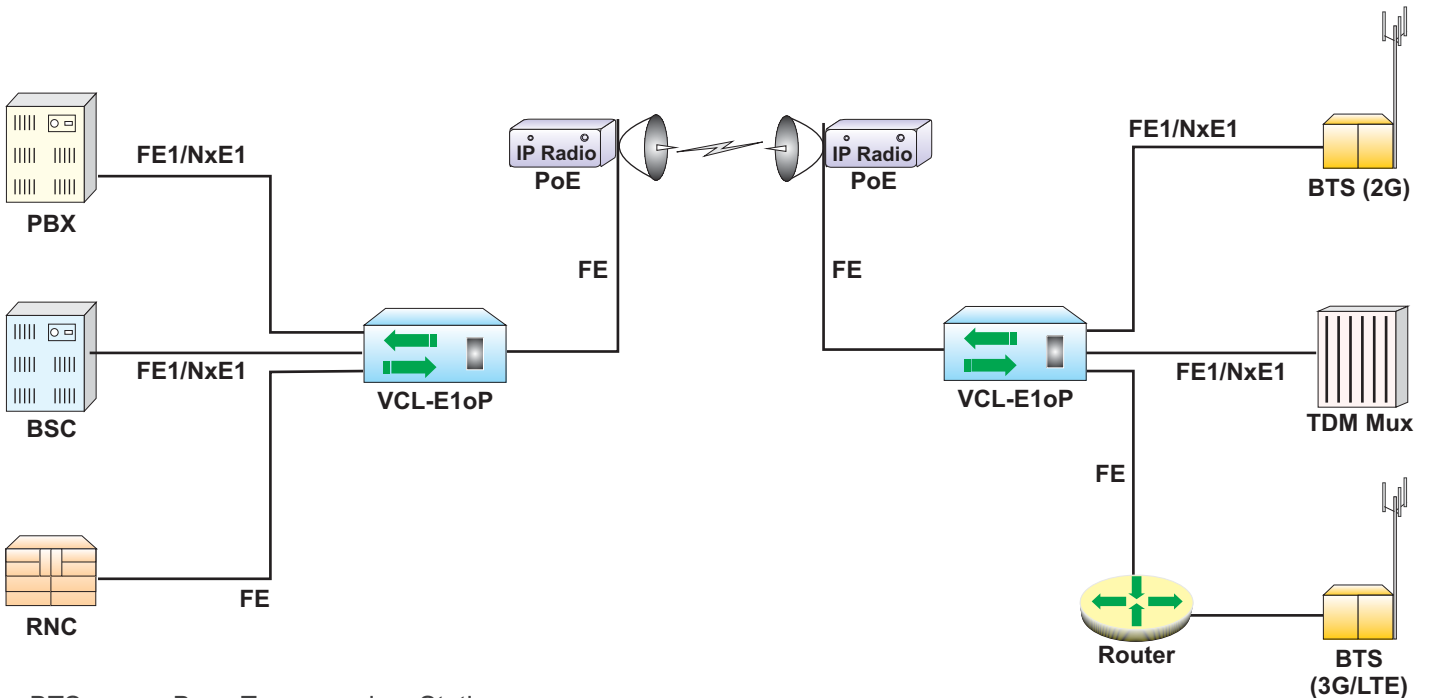

- BTS : Base Trans-receiver Station
- MSC : Master Switching Center
- RNC : Radio Network Controller
- LTE : Long Term Evolution
- FE1 : Fractional E1
- FE : Fast Ethernet
- GE : Gigabit Ethernet
- PoE : Power over Ethernet

Application Diagram

Typical Application in Wireless Network - 1+1 Link Redundancy

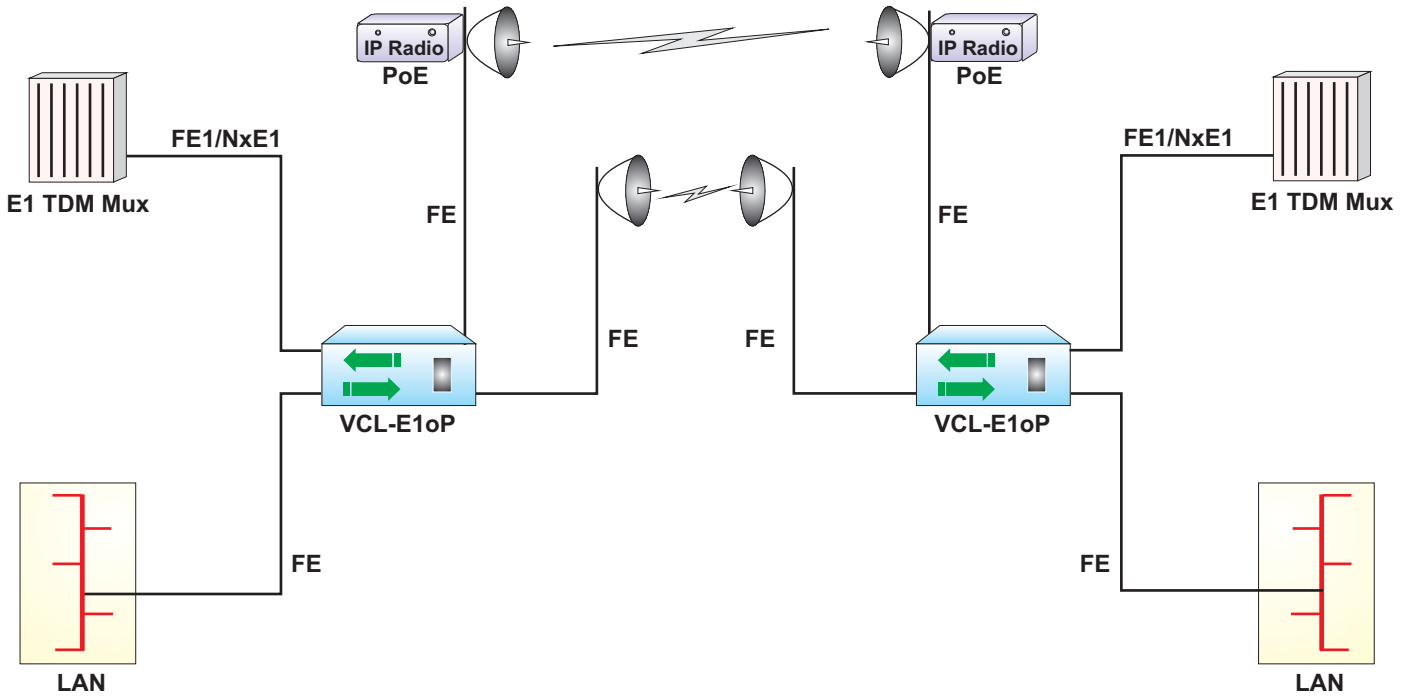

TDM over IP / Ethernet - Providing 2G/3G/LTE over an IP Cloud

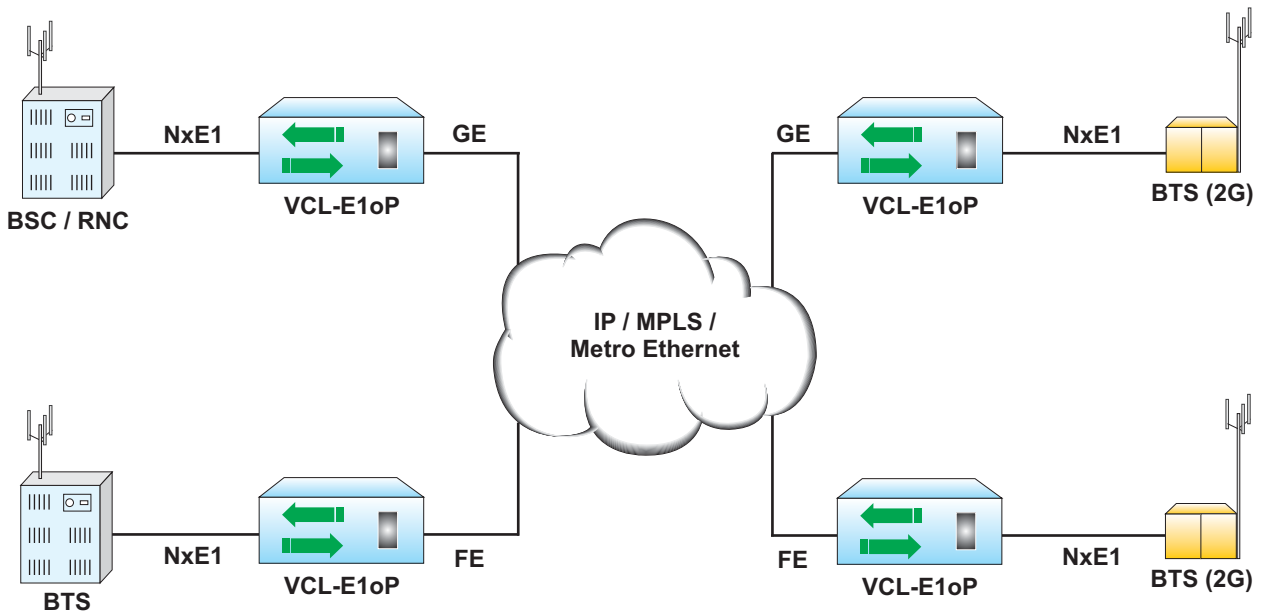

Application Diagram

TDM over IP with Fractional E1 (Support CESoPSN)

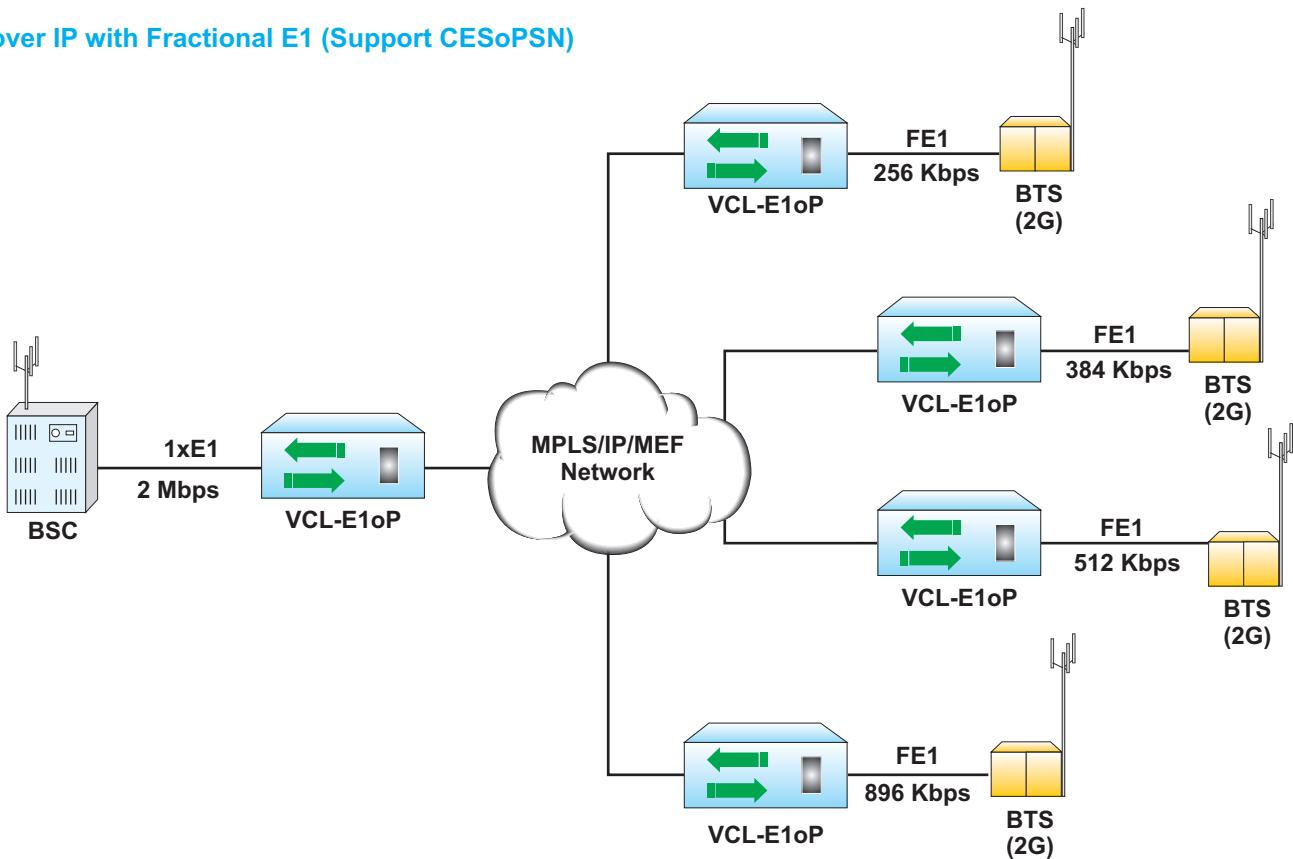

TDM over IP / Ethernet - VLAN Based Priority (Classifying Services)

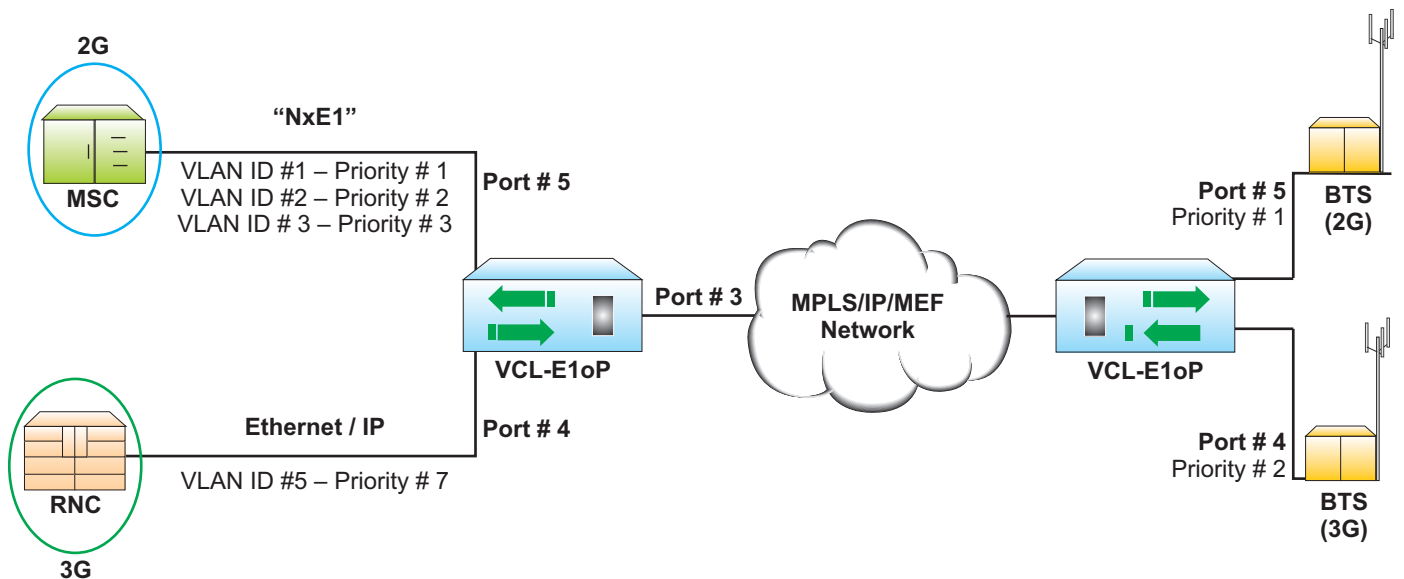

Notes:

- VLAN based Priority feature allows the user to assign priorities to VLANs carrying different types of services / traffic according based on user preferences.
- The user may configure the TDM traffic on highest priority and Ethernet service (3G data network) on a lower priority. User may also configure which TDM link should be given preference over the other TDM links when the uplink bandwidth decreases below a particular threshold.

Application Diagram

TDM over IP / Ethernet Port / Customers based bandwidth allocation (Port Rate Limiting)

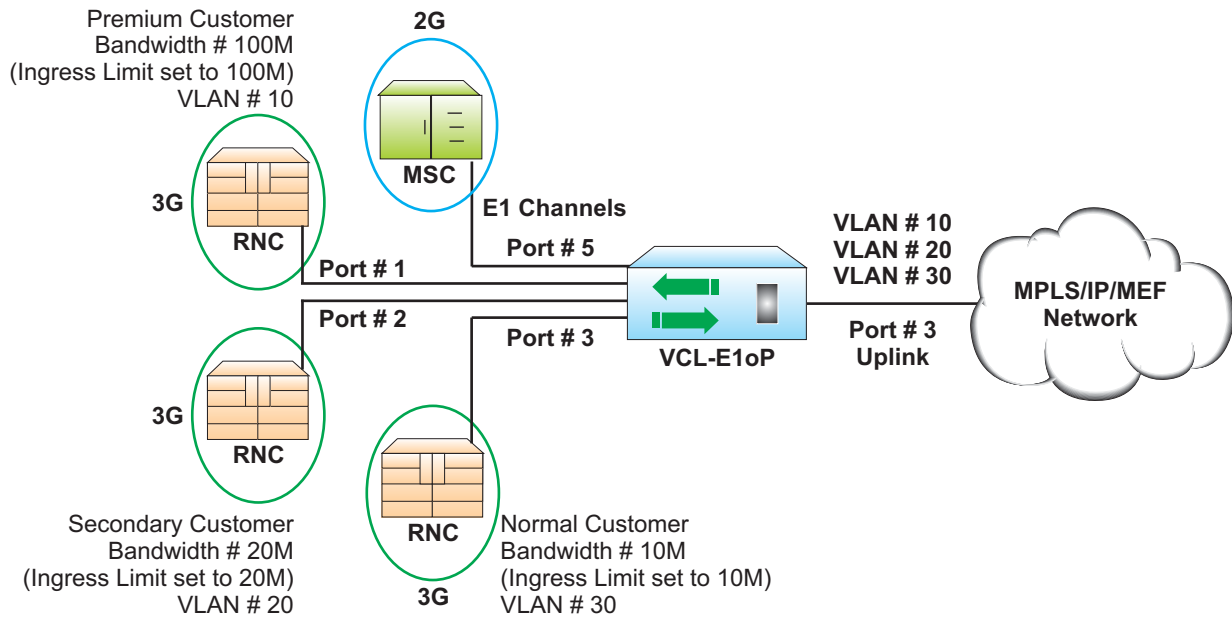

Notes: Port based Ingress Ethernet Rate Limiting allows the service provider to assigned the bandwidth as per customer requirements and separating their traffic by assigning 802.1Q based VLANs.

Technical Specifications

E1oP Specifications

Max number of E1 Ports	Number of Ports 4
Max number of logical links	Up to 24
Synchronization clock recovery	<ul style="list-style-type: none"> - Adaptive Clock Recovery recovery (ACLK) Options - Recovered Clock (RCLK) / Loop-Timed Clock - Asymmetrical (One-Clock and Two-Clock) Clock - Synchronization to an External Clock (ECLK) and an Internal Clock - Automatic fall back
Max number of Ethernet Ports	<ul style="list-style-type: none"> - 2 x FE (100BaseFX) Optical Ethernet (SFP) Ports - 2 x 10/100Base-T Electrical Ethernet Ports Or - 4 x 10/100Base-T Electrical Ethernet Ports
Supported Transport Mechanisms	ETF-PWE3, SAToP and CESoPSN
Supported PSN (Packet Switched Networks) type	UDP, IP, MPLS and MEF
QoS	802.1p packet priority

E1 Interface

Number of Ports	Number of Ports 4 (supporting 64Kbps upto 2.048Mbps on each port)
Framing Formats	Unframed, framed and Multi-frame (with or without CRC-4)
Line Coding	HDB3
Compliance	ITU-T G.703, G.704, G.706 and G.732
Jitter and Wander	Complies to ITU-T G.823, G.824
Line Impedance	120 Ohms balanced - Optional 75 Ohms
Protection	<ul style="list-style-type: none"> - Optional Metallic and Longitudinal Protection - ESD protection

Ethernet Interface

Number of Ports	4 x 10/100BaseT (Copper) Ethernet ports - Default <ul style="list-style-type: none"> - *2 x FE Copper Ports + 2 x FE PoE Ports - *2 x 100BaseFX Optical Ports + 2 x FE Copper Ports - *2 x 100BaseFX Optical Ports + 2 x FE PoE Ports *Optional
Electrical	10/100 Auto-negotiation/MDI-X (Auto-sensing), Full-Half Duplex, RJ45 Electrical Connector, PoE (Power of Ethernet) option on 2 x 10/100BaseT Ports
Protection	ESD protection
Optical	100Base-FX (Fast Ethernet), SFP
Power over Ethernet (PoE)	40 Watts per port
PoE Protection	Complies with Telcordia GR-1089-CORE Issue 6 Specifications and ITU-T K.44 (2012*) specifications
Maximum Frame Size	1500 Bytes

100BaseFX (Optical) Ethernet Specifications

Type	SFP
Compliance	<ul style="list-style-type: none"> - MSA Compliant - RoHS - EMI - ESD - DDM
Safety	Class 1 Laser Safety/ IEC-60825 Compliant
Bit Rate	100 Mbps
Wavelength	1310 / 1550 nm
Distance	550m to 120Kms, as per order
Optical Connector	LC

Power Consumption

Power Consumption	<15 Watts (without PoE) PoE 40 Watts per channel
-------------------	-----------------------------------------------------

Power Supply Options

- Dual Redundant
- 1+1 AC power (100 to 240V AC, 50/60 Hz)
- 1+1 DC (-48V) power (40 to 72V DC)
- 1+1 DC (-24V) power (18 to 40V DC)
- AC plus DC (AC + DC), AC or DC
- EMI/EMC compliant.

Note: * Excludes 0.76A (300 Ohms) and 0.38A (600 Ohms) and 0.23 (1000 Ohms) AC Power Cross.

Command Language

- Windows based GUI (Graphical User Interface).
- Command Line Interface (English text commands).

Management and Control Interfaces

- COM Port (RS232 Serial Port).
- 10/100BaseT Ethernet Port (each multiplexer may be assigned an IP address and connected to a LAN / IP network for remote access and management through the 10/100BaseT Ethernet Port for out-of-band configuration, management and access).
- Telnet.
- SNMP, V2.
- Additionally, a Windows based GUI (Graphical User Interface) for easy configuration, management and access.

AC Power Supply Specifications

Input AC Voltage	110 / 220 Volts AC
Range of input AC Voltage	100 V to 240 V AC, 50Hz/60Hz.
AC Input Connector	IEC Connector

24V DC Power Supply Specifications

Power Supply	24V DC
Range of input	18V to 40V DC
Input voltage reversal protection	Provided
Under voltage protection	< 4.85V
Over voltage protection	> 5.15V
Efficiency at full load	> 90% @ 5V/4A (when input voltage-24V)
Ripple at full load	< 5mVrms
Spike at full load	< 50mV

48V DC Power Supply Specifications

Power supply	-48V DC
Range of input	-40V DC to -72V DC
Under voltage protection	< 4.85V
Over voltage protection	> 5.15V
Efficiency at full load	> 91% @ 5V/2A (when input voltage -48V)
Ripple at full load	< 5mVrms
Spike at full load	< 50mV

Environment

Temperature	-20°C ~ +60°C for Operation
Humidity	5% to 95% (at 35°C) Non-condensing

Regulatory Compliance

- Safety - IEC 60950 Safety - IEC 60950
- CE
- RoHS
- Complies to ANS/IEC standards
- Complies with Telecom Part 68, FCC Part 15 and CISPR 22 Class A
- EMC EN55022: 1998 + A1 and A2
- EMC EN55024,
- Operation ETS 300 019 Class 3.2
- Storage ETS 300 019 Class 1.2
- Transportation ETS 300 019 Class 2.3

NMS (with Telnet) OAM port Specifications

Network Interface	RJ-45 Ethernet 10BaseT or 100BaseT-TX (auto sensing)
Compatibility	Ethernet Version 2.0 IEEE802.3
Protocols supported	ARP, UDP/IP, TCP/IP, Telnet, SNMP
Management	SNMP, Serial login, Telnet login

External Alarms

- Dry Contact Relay - 2 Form C
- Rated upto 72V DC, 1 Amp.

Chassis

- 1U High (44mm)
- 19-inch rack-mounting shelf
- Also available in Desktop / Table Top Version.

Mechanical Specification

Height	44 mm (1U)
Depth	260 mm
Width	480 mm (19 inch rack mountable)
Weight	3 Kgs.

Ordering Information

S. No.	Part #	Product Descriptions	Remarks
1	VCL-E1oP-4E1 FE-4EE-2130	VCL-4E1 over Ethernet Multiplexer (TDM over IP) 19-inch 1U High Rack Mount version Supports: - Upto 4 x E1 [RJ45 (F)] - 4 x Ethernet Ports [100Mbps, Electrical RJ45 (F)] - 1 x System Core Cables, Installation Accessories, Documentation, System User Manual / Disk (Set) - OAM [SNMP, Telnet (RJ45 Port) and Serial Port (DB-9 COM Port)] * Add Power Supply Option from below	CORE UNIT without PSUs
2	VCL-E1oP-4E1 FE-2OE-2130	VCL-4E1 over Ethernet Multiplexer (TDM over IP) 19-inch 1U High Rack Mount version Supports: - Upto 4 x E1 [RJ45 (F)] - 4 x Ethernet Ports (100Mbps) - 2 x Electrical Ethernet Ports [RJ45 (F)] - 2 x Optical Ethernet Ports [SFP based / without SFPs] - 1 x System Core Cables, Installation Accessories, Documentation, System User Manual / Disk (Set) - OAM [SNMP, Telnet (RJ45 Port) and Serial Port (DB-9 COM Port)] * Add Power Supply Option from below	
3	VCL-E1oP-4E1 FE-2PE-2130	VCL-4E1 over Ethernet Multiplexer (TDM over IP) 19-inch 1U High Rack Mount version Supports: - Upto 4 x E1 [RJ45 (F)] - 4 x Ethernet Ports (100Mbps) - 2 x Electrical Ethernet Ports [RJ45 (F)] - 2 x Power over Ethernet (PoE) Ports [RJ45 (F)] - 1 x System Core Cables, Installation Accessories, Documentation, System User Manual / Disk (Set) - OAM [SNMP, Telnet (RJ45 Port) and Serial Port (DB-9 COM Port)] * Add Power Supply Option from below	

Add OCXO option if required (Internal)

1	OCXO	Add High Stability Timing, Ultra Low Noise OCXO (oven-controlled crystal oscillator) optional	OCXO
---	------	--------------------------------------------------------------------------------------------------	------

Power Supply Options

1	AC220	1 x 100-240V AC Power Supply Input	Any One Option
2	DC048	1 x (-) 48V DC Power Supply Input	
3	ACDC	1 x 100-240V AC Power Supply Input 1 x (-) 48V DC Power Supply Input	
4	AC220R	2 x 100-240V AC Power Supply Input [Redundant]	
5	DC048R	2 x (-) 48V DC Power Supply Input [Redundant]	

Ethernet SFP Options

1	VCL-EMOD 0193	155Mbps Fast Ethernet SFP Transceiver Duplex LC, 1310nm, 15km, SMF	Maximum 2 SFPs per CORE UNIT As per Site Requirement.
2	VCL-EMOD 0194	155Mbps Fast Ethernet SFP Transceiver Duplex LC, 1310nm, 40km, SMF	
3	VCL-EMOD 0217	155Mbps Fast Ethernet SFP Transceiver Duplex LC, 1550nm, 80km, SMF	
4	VCL-EMOD 0156	155Mbps Fast Ethernet SFP Transceiver Duplex LC, 1550nm, 120km, SMF	
5	VCL-EMOD 0243	155Mbps Fast Ethernet SFP Transceiver Duplex LC, 1550nm, 150km, SMF	
6	VCL-EMOD 0171	155Mbps Fast Ethernet SFP Transceiver Duplex LC, 1550nm, 200km, SMF	

Cables and Accessories Options

1	VCL-HRNS 1280	1E1 75 Ohms Connectorized Cable [RJ45M-2BNC, 28cm]	As per Site Requirement.
2	VCL-HRNS 1229	Optical Patch Cord Connectorized Cable [2LC-2LC, 3m, SM]	
3	VCL-HRNS 1238	Optical Patch Cord Connectorized Cable [2LC-2LC, 10m, SM]	
4	VCL-HRNS 1242	Optical Patch Cord Connectorized Cable [LC-FC, 10m, SM]	
5	VCL-HRNS 1243	Optical Patch Cord Connectorized Cable [2LC-2FC, 10m, SM]	
6	VCL-HRNS 1239	Optical Patch Cord Connectorized Cable [LC-SC, 10m, SM]	
7	VCL-HRNS 1258	Optical Patch Cord Connectorized Cable [2LC-2SC, 10m, SM]	
8	VCL-ECON 1172	Connector (Attenuator LC-LC (10 db.))	
9	VCL-ECON 1173	Connector (Attenuator LC-LC (20 db.))	
10	VCL-ECON 1186	Connector (Attenuator FC-FC (10 db.))	
11	VCL-ECON 1187	Connector (Attenuator FC-FC (20 db.))	
12	VCL-ECON 1197	Connector (Attenuator SC-SC (10 db.))	
13	VCL-ECON 1198	Connector (Attenuator SC-SC (20 db.))	

- Note:**
1. SPFs to be added if 100BaseFX (Optical) Ethernet Ports are required.
 2. Redundant power supply to be added, if required.
 3. Select VCL-HRNS 1280 for E1 75 Ohms BNC (F).

Technical specifications are subject to changes without notice.
 All brand name and trademarks are the property of their respective owners.
 Revision 1.9 - February 12, 2016

U.K.

Valiant Communications (UK) Ltd
 1, Acton Hill Mews,
 310-328 Uxbridge Road,
 London W3 9QN, United Kingdom

E-mail: gb@valiantcom.com

U.S.A.

Valcomm Technologies Inc.
 4000 Ponce de Leon, Suite 470
 Coral Gables, FL 33146
 U.S.A.

E-mail: us@valiantcom.com

INDIA

Valiant Communications Limited
 71/1, Shivaji Marg,
 New Delhi - 110015,
 India

E-mail: mail@valiantcom.com