

VALIANT COMMUNICATIONS LIMITED

VCL-CBTM

Intelligent E1 Channel Bank



PRODUCT OVERVIEW

Valiant introduces its new intelligent E1 Channel Bank, VCL-CB with Voice Activity Detection (VAD) to provide voice activated "answer supervision" and "disconnect supervision" to connect VoIP (Voice over IP), Voice over Frame Relay and Voice over ATM networks to analog PSTN (POTS) lines that do not provide any type of answer supervision / battery reversal functions.

The interface to the analog PSTN (POTS*) lines have been ruggedized to provide complete protection against line card failures which occur from induced voltages from AC power lines and lightning strikes and difficult field conditions.

Valiant's intelligent E1 channel bank is especially designed for the VoIP (Voice over IP), Voice over Frame Relay and Voice over ATM network call-termination and long distance communications market that will terminate calls directly to the analog PSTN lines. The channel bank solution provides a cost-effective platform to convert upto 30 dial-up, analog (PSTN) voice circuits to a digital E1 interface to connect to VoIP (Voice over IP), Voice over Frame Relay and Voice over ATM Gateways.

Valiant's years of experience in providing telecom transmission solutions to customers worldwide, located in over 40 countries, has been build in to providing a cost-effective - yet an intelligent E1 channel bank solution.

The VCL-CB intelligent Channel Bank is especially useful for providing an analog interface to the latest servers from the following companies:

- Cisco ASXXXX Voice over IP servers
- Nuera 200 Voice over IP servers
- Mockingbird Voice over IP Servers
- Lucent ITS-SP, Voice over IP server
- Lucent PortMaster 3



- For long distance traffic termination on PSTN lines that "Support", or "Do Not Support" "Battery Reversal / Polarity Reversal" (Answer Supervision).
- Voice Activity Detection (VAD) to provide spoof "Answer Supervision"
- To provide "Disconnect Supervision" to disconnect hung PSTN lines.
- Provides complete line protection against difficult field conditions.
- Also used in conventional applications to deliver voice over an end-to-end E1 (radio / fiber / HDSL) links

The VCL-CB, E1 Channel bank offers all types of analog interfaces including FXO, FXS and 2W/4W E&M interfaces, that may be required to connect to an E1 digital interface of a VoIP (Voice over IP), Voice over Frame Relay and Voice over ATM Gateway.

The E1 Channel Bank shall interface to the E1 port of any VoIP Gateway / Switch / Server / PBX using R2 CAS (R2 Digital) Signaling (R2 Channel Associated Signaling) as per ITU-T Q.421 / Q.422 recommendations, to connect up to 30 analog interfaces to an E1 port.

Please consult factory for the complete list of compatible CISCO ASXXXX VoIP Servers.

VCL-CB-INT™ E1, Channel Bank

Remote Access Server / VoIP Gateway Application

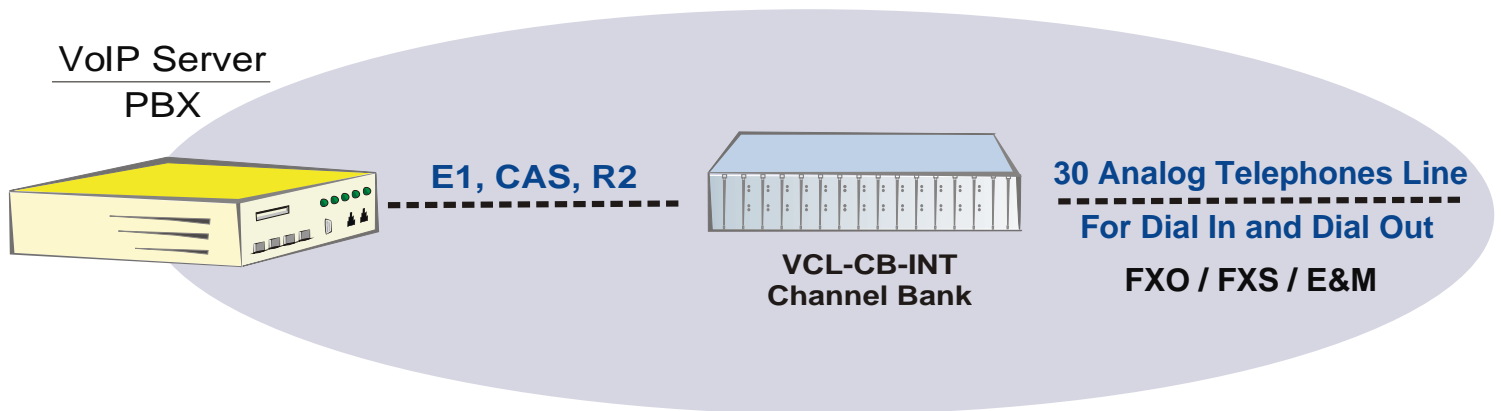

PRI ISDN Option Available

The cable plant of most telecom service providers is not designed to deliver E1 services to customers in most parts of the world. The VoIP Gateway / Switch / Server / PBX with an E1 interface, thus, in such cases can only be accessed through dial-up, 2 wire analog lines, the only available link for connecting the Exchange (Central Office) to the Corporate PBX Networks and VoIP (Voice over IP) Gateways.

Valiant's VCL-CB, intelligent E1 Channel Bank is especially useful in countries, where the cable plant is not equipped to deliver digital E1 services to the customer, who are using the next generation access equipment, which can only connect to an E1 interface.

The E1 Channel Bank solution is available in two versions:

VCL-CB-BR™

- a). The first E1 channel bank (VCL-CB-BR™) provides answer supervision when the called party answers, upon receiving an actual battery reversal of the PSTN analog line.

Both, the line connect and disconnect functions are provided using the actual battery reversal function of the PSTN analog line (e.g. much like your coin pay-phones).

Available with FXO, FXS and E&M interfaces.

VCL-CB-INT™

- b). The second E1 Channel Bank (VCL-CB-INT) is an intelligent E1 Channel Bank that provides the metering function using **Voice Activity Detection (VAD)** to provide voice activated "answer supervision" and "disconnect supervision". The VCL-CB-INT, intelligent E1 Channel Bank uses a sophisticated DSP algorithm to "listen" to the PSTN line for "voice activity" and will provide "answer supervision" information to initiate the metering process when the CALLED PARTY answers. It will also "listens" to the line to determine the end of a call (silence) to provide line the "disconnect supervision".

The VCL-CB-INT™ E1 Channel Bank is available with FXO interfaces which shall connect to the analog PSTN (POTS*) lines from the local Exchange / Telco / Switch.

* POTS: Plain Old Telephone Service

FEATURES:

- Used for terminating long distance traffic on PSTN lines that "**Support**" or "**Do Not Support**" "**Battery Reversal / Polarity Reversal**" (**Answer Supervision**).
- Uses sophisticated DSP algorithms to provide **Voice Activity Detection (VAD)** to provide "Answer Supervision" to initiate metering and "Disconnect Supervision" feature to "Disconnect hung / stuck PSTN lines".
- Ruggedized equipment design.
- Provide complete protection against the line card failures occurring from induced voltages from AC power lines and lightning strikes and other difficult field conditions.
- VF (Voice Frequency) specifications are in accordance with G.712, ITU-T recommendations to provide clear voice.
- Ideal choice for long distance call / traffic termination operators, corporate and ISP customers, who wish to connect their fully digital networks to the PSTN, through the available analog dial-up PTT lines.
- Available with an E1, 2Mbps interface or a fractional E1 interface (to even start service with less than 10 lines).

HIGHLIGHTS:

- Ideal for long distance traffic termination.
- Also used in conventional applications to deliver voice over an end-to-end E1 (radio / fiber / HDSL) links.
- Available with FXO, FXS and 2W/4W E&M customer interfaces.
- Compliance to all the relevant ITU-T recommendations.
- Modular, 3U high, compact construction provides easy maintenance.
- Plug & Play - easy to install equipment.
- Extensive set of alarms
- Available with easy to use Windows™ based Graphical User Interface.
- Synchronization to different user selectable clock sources.
- Remote Access through TCP/IP (for remote configuration and monitoring - available as an optional extra).

Ordering Information**Core System Composition:
(Common Equipment)**

- 19-Inch Chassis
 - -48VDC Power Supply Card
 - Control Card, E1 Interface Card
 - Control Card, E1 Interface Card
 - Ring Generator - Optional*
- * Required only with FXS Interface Card

Part #

VCL-CB-000/005
 VCL-CB-010
 VCL-CB-015-INT
 VCL-CB-015-BR
 VCL-CB-040

User Interface Cards:

- | | |
|--|----------------|
| • FXO (Central Office Interface Card) | VCL-CB-030-INT |
| • FXO (Central Office Interface Card) | VCL-CB-030-BR |
| • FXS (Remote / Subscriber Interface Card) | VCL-CB-025 |
| • E&M (2 Wire / 4 Wire Interface Card) | VCL-CB-035 |

Notes:

FXO interface cards - connect to the analog PSTN (telco) lines.
 FXS interface cards - connect to analog telephone sets.
 E&M interface cards - connect to E&M switches / interfaces.

TECHNICAL SPECIFICATION

Digital Interface 2.048 Mbps, E1 Interface

Number of E1 Interfaces	1
Conformity (Electrical)	G. 703
Frame Structure	As per ITU (CCITT) G.704
Signaling	Channel Associated Signaling , (R2 Gen) R2 Generic in accordance with ITU-I Q.421 / Q.422 Rec. PRI ISDN (Euro ISDN) signaling as per ITU-T Rec. Q.921, Q.931 (Optional Extra)
PCM Sampling Rate	8000 samples/sec
Encoding Law	A Law as per ITU (CCITT) G.823
Bit Rate	2048 Kbps \pm 50 ppm
Code	HDB3
Nominal impedance	120 balanced (75 Ω unbalanced - option on request)
Connector	RJ-45 (120 ohms impedance)
Peak Voltage of a mark	
For 120 Ω Balanced interface	3.0 V \pm 0.3 V
75 Ω Unbalanced interface	2.37 V \pm 0.237 (Optional)
Peak Voltage of a space	
For 120 Ω Balanced interface	0V \pm 0.3V
75 Ω Unbalanced interface	0V \pm 0.237 V
Nominal Pulse Width	244ns
Pulse Mask	As per ITU (CCITT) Rec. G.703
Output Jitter	<0.05 UI (in the frequency range of 20Hz to 100 KHz)
Permissible Attenuation	6dB at 1 MHz
Return Loss at:	
51.2 KHz to 102.4 KHz	>12dB
102.4 KHz to 2048 KHz	>18dB
2048KHz to 3072KHz	>14dB
Jitter Tolerance	As per ITU (CCITT) G.823
Loss and recovery of frame alignment :	As per clause 3 of ITU (CCITT) G.732
Loss and recovery of multi frame alignment:	As per clause 5.2 of ITU (CCITT) G.732

2 Wire , Analog Interface - FXO, FXS and E&M Interface(s)

Number of Interfaces per card	2
Interface Type(s)	FXO, FXS and 2W / 4W E&M
Maximum Number of Channels	30
Transmission performance	Fully compliant to ITU (CCITT) G.712 specifications
Line Impedance	600 (900 Ω optional)
Connector	RJ-11
Voice Channel Frequency	300Hz-3400Hz
Insertion Loss	-2dB Nominal (User adjustable range of -2dB to -7dB)
Idle Channel Noise	\leq -65dB
Return Loss	300 Hz - 600Hz \geq 12dB 600Hz - 3400Hz \geq 15 dB
Longitudinal Balance	\geq 46dB between 300Hz to 3400Hz
Ring frequency detection (FXO)	25Hz and 20 Hz
Ring voltage detection (FXO)	\geq 30 volts RMS

Ring Voltage (FXS)	≥40 volts RMS into a load of 5 R.E.N. with a 0.30 Erlang traffic pattern
Subscriber Loop Current (FXS)	≥23mA into a subscriber loop of 1000 ohms
Pulse Dialing Speed	8-12 pps
Overload Level	+3.14 dBm ± 0.5 dBm
Data Transmission	Supports V.34 modems 33.6Kbps (download data transmission rate)

G.703 @ 64kbps, Synchronous Data Interface

Number of Interfaces per Card	2
Maximum Number	30, V.35, 64Kbits / sec. Interface
Conformity	To (CCITT) Rec. G.703
Mode	Synchronous, Co-directional
Bit Rate	64Kbps

iDSL - ISDN DSL Specifications

"U" Interface	Meets ANSI T1.601-1992 requirements
Line Rate	160 Kbits/s
Frame Format	2B as per CCITT Rec.1.430
Line Code	2B1Q as per CCITT Rec.G.961
Accepted Line Attenuation	42dB at 40 KHz
Pulse Shape	As per CCITT Rec.G.961
Multiplexer Emulation	LT Emulation
Customer Premises Equipment	NT Emulation
Impedance	135 Ohms at 40KHz

Customer Premises Desktop User Interfaces:

Customer Premises Desktop Interfaces - Option # 1: (V.35 interface @ 128Kbps)

Our CO / ISP side iDSL Modem cards - part # VCL-30-080 may be used with our V.35, baseband modem - Valiant Part # VCL-30-090 (customer premises desk top equipment with V.35 Interface @ 128Kbps).

Customer Side / Remote / Side Desk-Top Equipment: Provides 128Kbps data transmission rate on a twisted pair upto 5KM from the VCL-30, Installation Site: Customer Interface - V.35 data interface @ 128Kbps

Power Supply 110VAC-220VAC, 50Hz/60Hz, UL and CE Approved.

Ordering Information: Valiant Part # VCL-30-090 (desk-top customer premises equipment with V.35 interface @ 128Kbps).

Optional Accessories:

V.35 Data Interface Cable (with male / female M34 connector)

Customer Premises Desktop Interfaces - Option # 2: (10BaseT Ethernet - with IP Protocol Routing Functionality)

Our CO / ISP side iDSL Modem cards - part # VCL-30-080 may be used with our customer premises equipment with a 10BaseT Interface. Valiant Part # VCL-30-095 - customer premises desk top equipment with 10BaseT Interface - IP Protocol Routing Functionality. (Firewall Protection - Optional).

Customer Side / Remote / Side Desk-Top Equipment: Provides 128Kbps data transmission rate on a twisted pair upto 5KM from the VCL-30, Installation Site: Customer Interface - 10BaseT Ethernet Interface with IP Protocol Routing Functionality. The 10BaseT Interface may be directly connected to a 10BaseT Network Interface Card installed on a PC, or to to a HUB to connect a complete customer LAN to the network.

Power Supply 110VAC-220VAC, 50Hz/60Hz, UL and CE Approved.

Ordering Information: Valiant Part # VCL-30-095 (desk-top customer premises equipment with 10BaseT interface).

Maximum Distance : 5KM (4 miles) on 0.5 mm twisted Pan. Distance may vary with cable gauge

For distance using various cable guages please refer to chart below.

Distance in Kms. (Miles)				
Data Rate (Kbps)	Wire Gauge (AWG/mm)			
	19 (.9mm)	22 (.6mm)	24 (.5mm)	26 (.4mm)
128	17.4 (10.8)	11.6 (7.2)	8.1 (5.0)	5.5 (3.4)

PROTECTION

Central Office Terminal and Remote Terminal are protected against power surges and transients occurring from lightning and electric induction as per CCITT Rec. Table I/K-20 towards line side

Clock Synchronization

Synchronization Sources	Internal Clock or timing derived From the E1 HDB3 link (Loop-Timed)
External Clock Input	As per ITU (CCITT) Rec G.703
Default Option	Internal Clock

Power Supply

Input DC voltage	-48V DC (nominal)
Range of Input	-40V to -60V DC
Input Voltage Reversal Protection	Provided

